

ADVANTAGE

TRAILER RENTALS

DRY VAN SEMI TRAILER RENTALS



53' DRY VAN SEMI TRAILER RENTALS

USE:	STANDARDS:	
Retail	Length 53 ft	Door Type:
Manufacturing	Width 96 - 102 inches	Swing door
Construction	Height 13.6 ft	Roller door
Distribution	CAPACITY:	
Warehouse	53 ft Length, Gross, Weight: 45,000 lbs	
Transportation	53 ft Max Pallets: 26 pallets	

48' DRY VAN SEMI TRAILER RENTALS

USE:	STANDARDS:	
Retail	Length 48 ft	Door Type:
Manufacturing	Width 96 - 102 inches	Swing door
Construction	Height 13.6 ft	Roller door
Distribution	CAPACITY:	
Warehouse	48 ft Length, Gross Weight: 45,000 lbs	
Transportation	48 ft Max Pallets: 24 pallets	

OVERALL INTERIOR REAR DOOR CAPACITY MAX WEIGHT

OVERALL			INTERIOR			DOOR HEIGHT		CAPACITY	TARE WEIGHT
LENGTH	WIDTH	HEIGHT	LENGTH	WIDTH	HEIGHT	WIDTH	HEIGHT		
48 ft	102"	13' 6"	47' 6"	98.5"	100.6"	98"	100.6"	3,465 cu ft	13,500 lbs
53 ft	102"	13' 6"	47' 6"	98.5"	108"	94"	102"	3,489 cu ft	13,500 lbs

ADVANTAGE

TRAILER RENTALS

DRY VAN SEMI TRAILER RENTALS

SWING DOOR

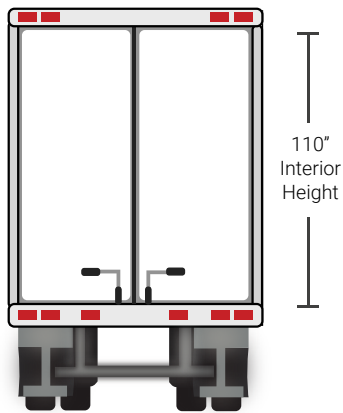
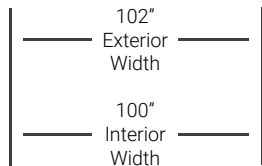

Door Opening
98" x 110"

ROLL DOOR

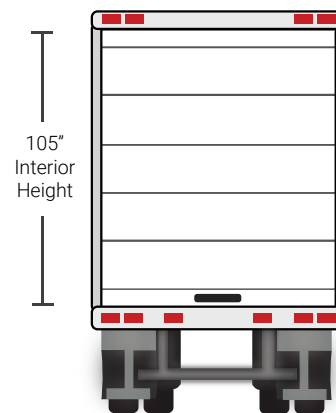
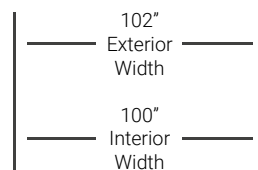



Door Opening
98" x 110"

*Data provided for illustrative purposes only. Actual equipment in use varies by carrier and manufacturer.
This is only a guide and should not be used as a definitive reference for dock planning.*

For more information on rentals contact us at:

 www.advantagerents.com

 (214) 637-4506

 info@advantagerents.com